

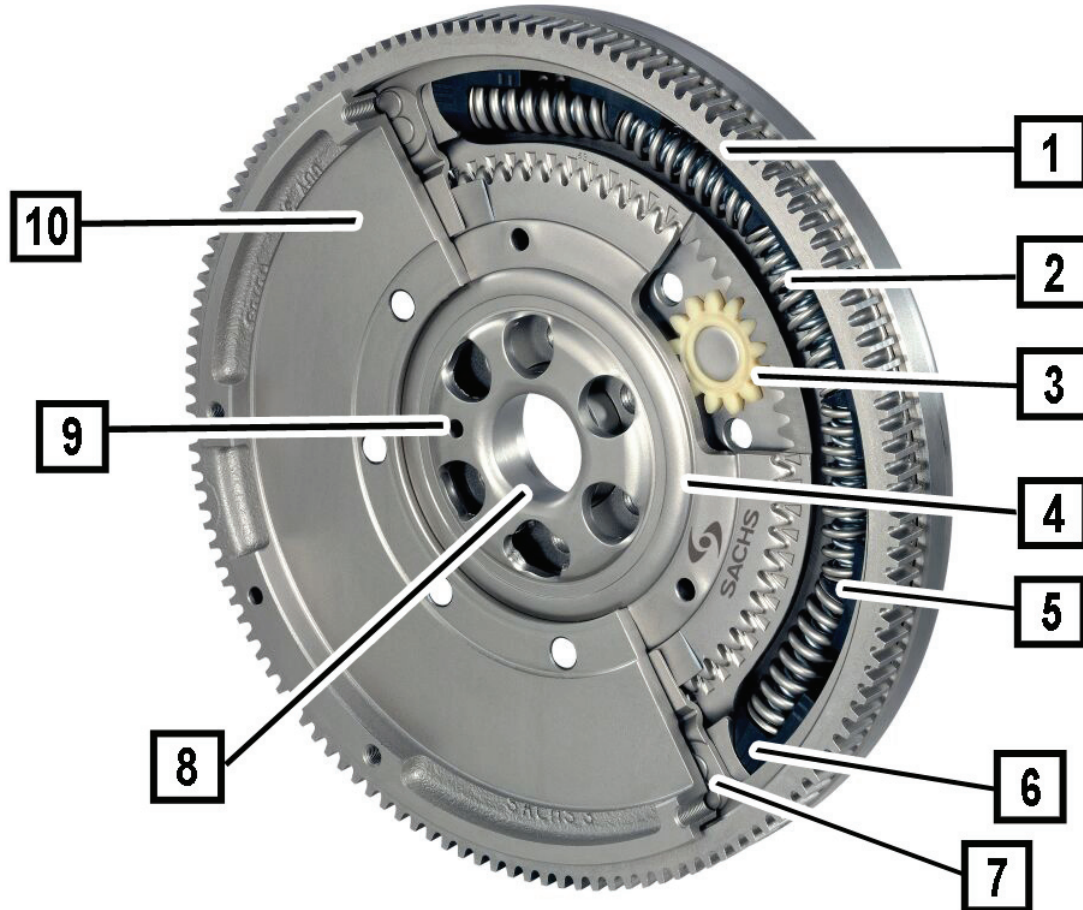

Dual-mass flywheels decrease noise and improve refinement on the move.



1) Primary flywheel; 2) Springs; 3) Planetary gear; 4) Plain bearing, axial; 5) Sliding shoe; 6) Spring cap; 7) Cover plate to retain grease content; 8) Plain bearing, radial; 9) Hole for securing pin; 10) Secondary flywheel



### NOTE

- Clean the dual-mass flywheel with oil- and grease-free rags only. High-pressure cleaners, steam jets, cleaning sprays or compressed air must not be used. That could lead to dirt or cleaning agents getting inside the dual-mass flywheel and causing increased wear.
- For technical reasons, the secondary flywheel (10) friction area must not be reworked!
- The primary (1) and secondary flywheel (10) have to be prevented from rotating with a 6mm-pin (9) before removing it from the crankshaft. If this is omitted, the secondary flywheel could be damaged by a bolt head.
- Always renew the crankshaft connecting bolts. Please observe the tightening torques for the bolts. Observe the vehicle manufacturers' instructions (expansion bolts, securing material).
- When replacing the clutch for the second time, always replace the dual-mass flywheel as well. The torsion damper in the dual-mass flywheel is also wear component.



### Testing

When installed, the primary and secondary flywheels can be rotated against each other by hand. Measured on the external diameter of the dual-mass flywheel, the rotation of the secondary flywheel amounts to 10 mms clockwise and 10 mms counter-clockwise. Rotation tolerance must be equal in both directions. In any case, the secondary flywheel has to turn back to its original position by itself.

### Possible causes of damage / failure of the dual-mass flywheel

- Frequent stalling of the engine
- Driving at extremely low engine speeds
- Irregular operation of the ignition and fuel injection systems
- Different compression pressures in various cylinders
- Extreme vibration due to worn drivetrain components
- Overheating

### Indicators for mandatory replacement:

#### Overheating of secondary flywheel



#### Cause:

Caused by incorrect clutch use, e.g. clutch slip.

#### Result:

- Heat counteracts the effect of the damping grease. Sliding shoes, spring caps and springs run dry.
- Vibration damping performance is reduced or fails.
- Heat spots can cause clutch grabbing.

#### Please note:

Clearly visible annealing discoloration and heat cracking.



### Primary flywheel worn through

**Cause:**

Extreme mechanical strain on entire DMF. This may be due to a rough running engine, e.g. caused by faulty injectors.

**Result:**

- Destruction of interior components
- In extreme cases, internal components wear through the housing of the primary flywheel. This leads to total failure of the DMF.

**Please note:**

Lubricant leakage is another sign of this problem.

### Signs of overheating inside on the secondary flywheel

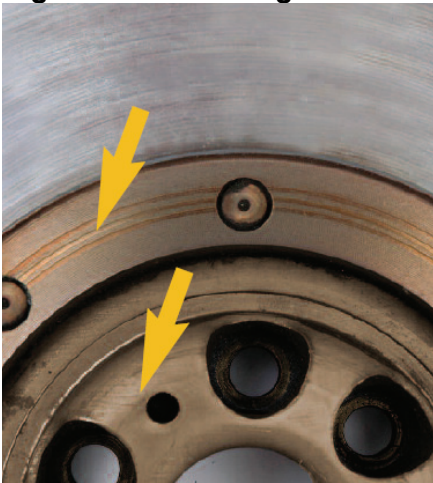
**Cause:**

Thrust bearing wear between primary and secondary flywheel due to mechanical strain.

**Result:**

Heat counteracts the effect of the damping grease. Sliding shoes, spring caps and springs run dry.

**Please note:**

Clearly noticeable by the temper colors, as well as the unusual vehicle noise that gets stronger when disengaging the clutch.

### DMF blocked

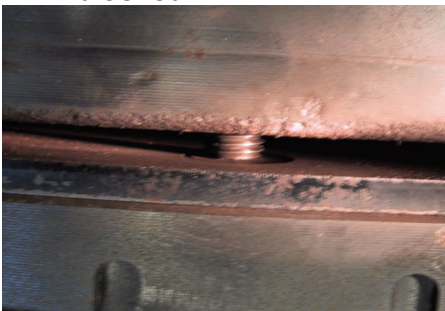
**Cause:**

Excessively long screws used to fit the cover assembly can block the primary and secondary flywheels.

**Result:**

- Vibrations cannot be dampened
- Noise levels cannot be reduced